

Surname	Centre Number	Candidate Number
Other Names		2



## GCE A level

1325/01



## PHYSICS – PH5 Electromagnetism, Nuclei & Options

A.M. TUESDAY, 28 June 2016

1 hour 45 minutes

### ADDITIONAL MATERIALS

In addition to this paper, you will require a calculator, a **Case Study Booklet** and a **Data Booklet**.

### INSTRUCTIONS TO CANDIDATES

Use black ink or black ball-point pen. Do not use pencil or gel pen. Do not use correction fluid.

Write your name, centre number and candidate number in the spaces at the top of this page.

Write your answers in the spaces provided in this booklet. If you run out of space, use the continuation page at the back of the booklet, taking care to number the question(s) correctly.

### INFORMATION FOR CANDIDATES

This paper is in 3 sections, **A**, **B**, and **C**.

Section A: 60 marks. Answer **all** questions. You are advised to spend about 1 hour on this section.

Section B: 20 marks. The Case Study. Answer **all** questions. You are advised to spend about 20 minutes on this section.

Section C: Options; 20 marks. Answer **one option only**. You are advised to spend about 20 minutes on this section.



JUN1613250101

**SECTION A**

*Answer all questions.*

1. Polonium-211 decays to lead-207 with a decay constant ( $\lambda$ ) of  $1.343 \text{ s}^{-1}$ .

(a) Calculate the half-life of polonium-211. [2]

.....

.....

.....

.....

(b) Calculate the initial activity of  $4.22 \times 10^{-11} \text{ kg}$  of polonium-211. (The molar mass of polonium-211 is  $0.211 \text{ kg mol}^{-1}$ .) [3]

.....

.....

.....

.....

.....

.....

(c) Calculate the percentage of polonium-211 nuclei remaining after 2.4 s. [2]

.....

.....

.....

.....



(d) Calculate the time taken for the number of polonium nuclei to decrease to 0.1% of their initial number. [2]

.....

.....

.....

.....

(e) Explain why  $4.22 \times 10^{-11}$  kg of polonium-211 could be highly dangerous even though it emits alpha particles which cannot penetrate human skin. [2]

.....

.....

.....

.....

1325  
010003



2. An oxygen fusion reaction that occurs in red supergiants is given below.

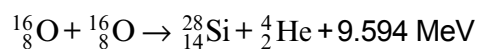

$$\text{mass of } {}^{16}_8\text{O} = 15.9905 \text{ u}, \quad \text{mass of } {}^4_2\text{He} = 4.0015 \text{ u}$$

- (a) Calculate the binding energy **per nucleon** of a  ${}^{16}_8\text{O}$  nucleus. [3]

$$\text{mass of neutron} = 1.0087 \text{ u}, \quad \text{mass of proton} = 1.0073 \text{ u}, \quad 1 \text{ u} = 931 \text{ MeV}$$

.....

.....

.....

.....

.....

.....

- (b) Taking account of the energy released in the reaction, calculate the mass of a  ${}^{28}_{14}\text{Si}$  nucleus to 6 significant figures. [4]

.....

.....

.....

.....

.....

.....

.....

.....

.....

.....



- (c) Explain without calculation, whether the total binding energy of  ${}_{14}^{28}\text{Si}$  and  ${}_{2}^4\text{He}$  is greater or less than that of two  ${}_{8}^{16}\text{O}$  nuclei. [3]

.....

.....

.....

.....

.....

.....

- (d) The following nuclear reaction would release considerably more energy but cannot occur.

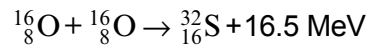

Explain why this is impossible in terms of **simple conservation laws**. (Hint: consider the following set up.) [3]



.....

.....

.....

.....

.....

.....



3. (a) Calculate the capacitance of the combination of capacitors shown. [3]

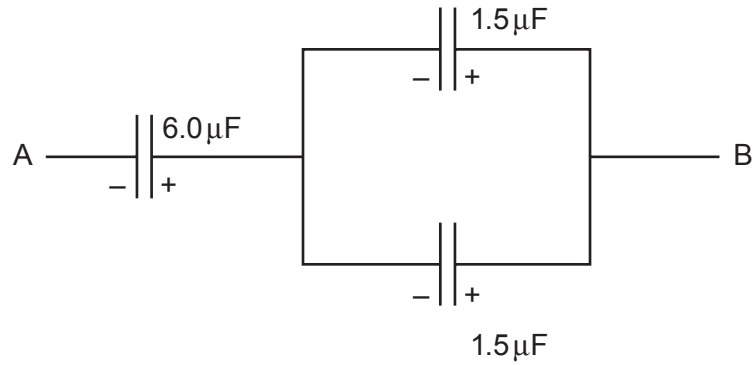

.....

.....

.....

.....

.....

- (b) Explain why the  $6.0\ \mu\text{F}$  capacitor stores the same amount of energy as one of the  $1.5\ \mu\text{F}$  capacitors. [2]

.....

.....

.....

.....

.....



(c) When the  $6.0\ \mu\text{F}$  capacitor is discharged through an unknown resistor, its charge drops from  $74.4\ \mu\text{C}$  to  $37.2\ \mu\text{C}$  in a time of 35 ms. Calculate:

(i) the unknown resistance; [3]

.....

.....

.....

.....

.....

(ii) the initial current in the circuit as the  $6.0\ \mu\text{F}$  capacitor discharges. [3]

.....

.....

.....

.....

.....

.....

.....

.....

.....

.....

1325  
010007



4. (a) State the laws of electromagnetic induction (Faraday's law and Lenz's law). [2]

.....

.....

.....

.....

.....

.....

- (b) A strong magnet drops vertically through a flat coil.

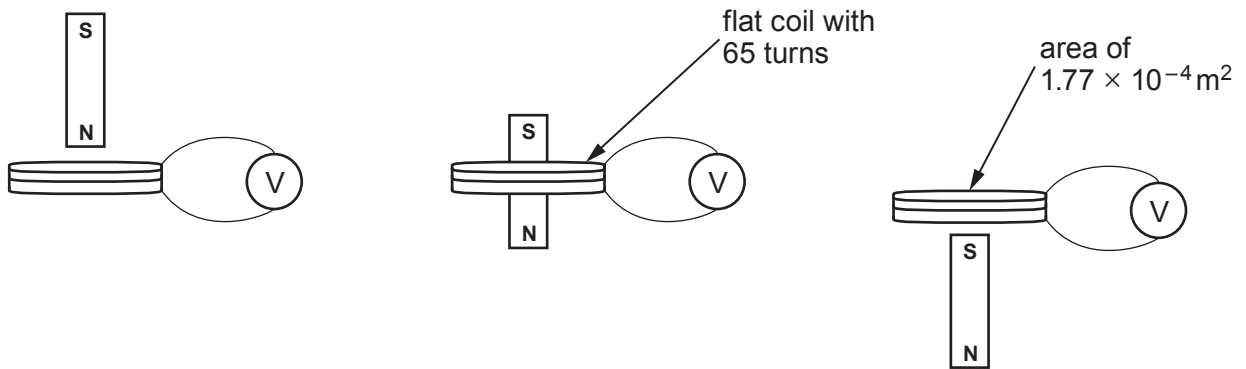

The emf induced in the coil is recorded using a voltmeter.

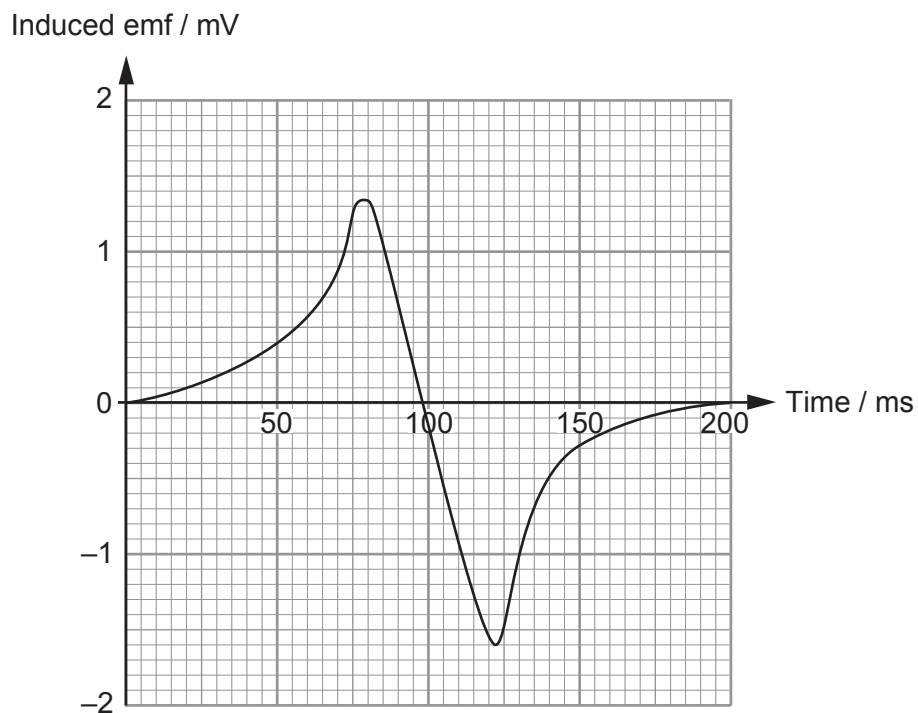



- (i) Use the laws of Faraday and Lenz to explain why the measured emf varies as shown in the graph opposite. [3]

.....

.....

.....

.....

.....

- (ii) The voltmeter is now removed and the ends of the flat coil connected so that current can flow. Sketch a graph showing the variation of force exerted by the coil on the magnet against time (no calculations are required). [3]

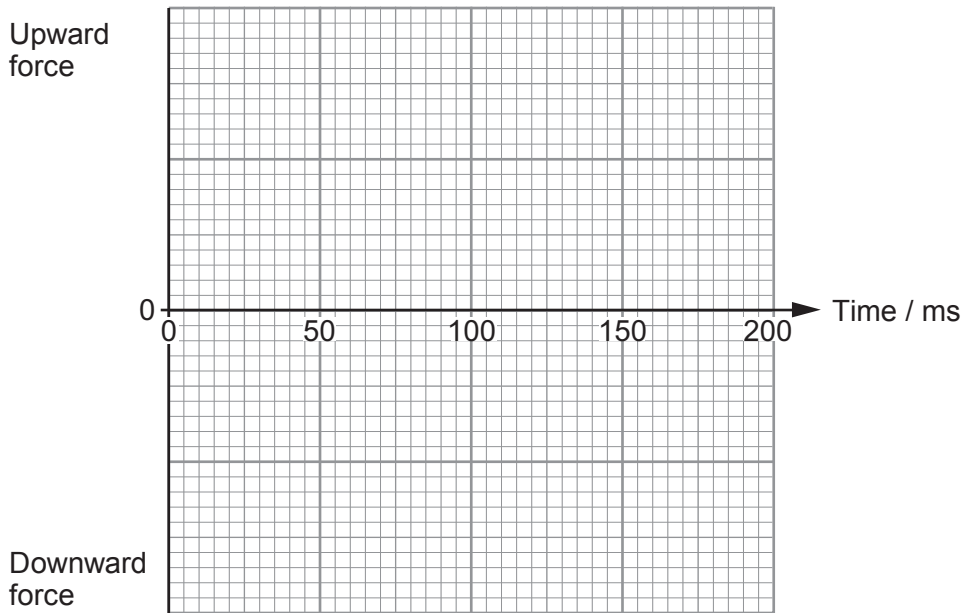

- (iii) Use the data in the diagrams of the dropping magnet on the opposite page to calculate the length of wire used to make the coil. [3]

.....

.....

.....

.....

.....

1325  
010009



5. (a) An electron-positron pair is produced by a photon of energy 1.04 MeV.

(i) Show that the energy required to produce an electron-positron pair is 1.02 MeV. [2]

.....

.....

.....

.....

(ii) State what happens to the remaining 0.02 MeV of the photon energy in this electron-positron pair production. [1]

.....

.....

(b) Point P is half way between two long wires each carrying a current of 19 A and 18.0 cm away from a third long wire carrying a current of 50 A. Show that the resultant magnetic flux density due to the **three** long wires at point P is approximately  $6 \times 10^{-5}$  T and **state its direction**. [4]

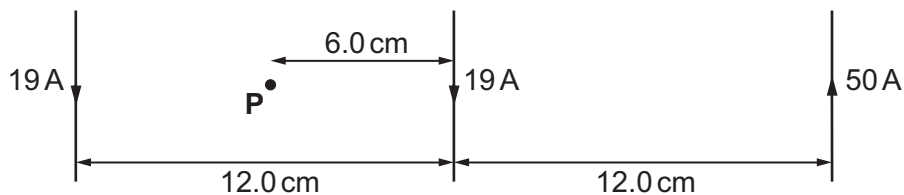

.....

.....

.....

.....

.....

.....

.....

.....

.....

.....

.....



(c) A positron travels with velocity,  $v$  perpendicularly to a uniform magnetic field,  $B$ .

(i) Show in clear steps that the radius of the circular motion of the positron is given by: [4]

$$r = \frac{m_e v}{Be}$$

.....

.....

.....

.....

.....

.....

(ii) Calculate the radius of motion of a positron moving perpendicularly to a uniform magnetic flux density ( $B$ ) of  $6.0 \times 10^{-5}$  T when the speed of the positron is  $6.0 \times 10^7 \text{ms}^{-1}$ . [1]

.....

.....

.....

(iii) Hence, explain why a positron produced at point **P** initially moving to the left will not travel with uniform circular motion. [2]

.....

.....

.....

.....



**SECTION B**

*Answer all questions.*

The questions refer to the case study.  
Direct quotes from the original passage will not be awarded marks.

6. (a) Describe very briefly the evidence Edwin Hubble gathered and how it supports the Big Bang Theory (paragraphs 3 and 10). (Do not include a diagram in your answer.) [3]

.....

.....

.....

.....

.....

.....

- (b) What does the author mean when it is stated that ‘... *particles were at relativistic speeds*’? (paragraph 5). [1]

.....

.....

- (c) Explain briefly why ‘*baryogenesis, a reaction that we know little about*’ is required to explain the current content of the universe (paragraph 5). [2]

.....

.....

.....

.....

.....

.....



(d) Explain why the production of electron-positron pairs stops at a later time than proton-antiproton pairs (paragraph 6). [2]

.....

.....

.....

.....

(e) Explain briefly what the term '*Big Bang nucleosynthesis*' means and what enabled this process to take place (paragraph 7). [2]

.....

.....

.....

(f) In your own words, explain briefly why the universe became transparent after 380 000 years (paragraph 8). [3]

.....

.....

.....

.....

.....

.....

(g) Show clearly how **equation 3** is derived (paragraphs 10-12). [3]

.....

.....

.....

.....

.....

.....

1325  
010013



(h) Use **equation 3** to confirm that the critical density of the universe corresponds to around 5 hydrogen atoms per cubic metre (paragraphs 10-12). [2]

.....

.....

.....

.....

(i) Use **figure 2** to confirm that the mean temperature of the universe is approximately 2.725 K. [2]

.....

.....

.....

.....

.....

.....



**SECTION C: OPTIONAL TOPICS**Option A: **Further Electromagnetism and Alternating Currents**Option B: **Revolutions in Physics – Electromagnetism and Space-Time**Option C: **Materials**Option D: **Biological Measurement and Medical Imaging**Option E: **Energy Matters**

Answer the question on **one topic only**.

Place a tick (✓) in one of the boxes above, to show which topic you are answering.

**You are advised to spend about 20 minutes on this section.**



**Option A: Further Electromagnetism and Alternating Currents**

7. (a) (i) Explain how the design of a transformer reduces energy losses. [4]

.....

.....

.....

.....

.....

.....

.....

.....

- (ii) Suggest why transformers employing superconducting coils might be beneficial even though there is considerable cost in liquid nitrogen for cooling. [1]

.....

.....

.....

- (b) In the following circuit, both the  $Q$  factor and the resonance frequency can be changed by changing the capacitance between the values shown in the diagram. However, the inductance and resistance are constant.

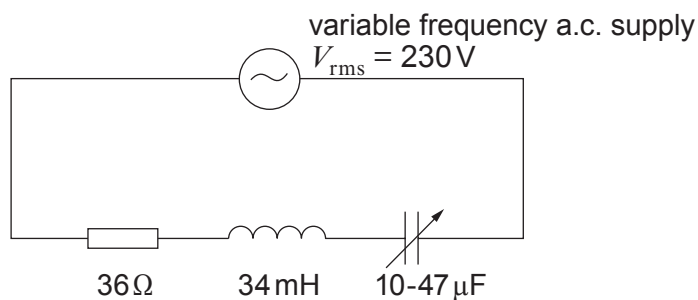

- (i) Show that the maximum and minimum resonance frequencies of the above circuit are approximately 273 Hz and 126 Hz respectively. [3]

.....

.....

.....

.....

.....

.....

.....





(ii) Explain what happens to the  $Q$  factor of the circuit when the capacitance is increased. [2]

.....

.....

.....

.....

(iii) Calculate the rms pd across the  $10\mu\text{F}$  capacitor at the maximum resonance frequency of 273 Hz. [4]

.....

.....

.....

.....

.....

.....

.....

.....

.....

.....

1325  
010017



- (iv) Explain why the rms pd across the  $47\ \mu\text{F}$  capacitor at the minimum resonance frequency of  $126\ \text{Hz}$  is less than that calculated in (b)(iii). [3]

.....

.....

.....

.....

.....

.....

.....

- (c) In the high pass filter shown, calculate the output pd ( $V_{\text{out}}$ ). [3]

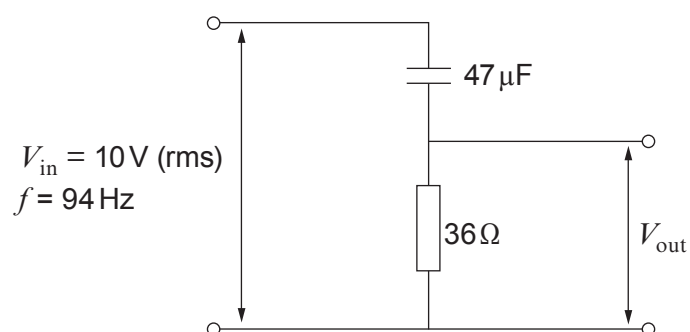

.....

.....

.....

.....

.....

.....

.....



**BLANK PAGE**

**PLEASE DO NOT WRITE  
ON THIS PAGE**



**Option B: Revolutions in Physics – Electromagnetism and Space-Time**

8. (a) In the following passage, Thomas Young explained the positions of the fringes formed when light from a single source is diffracted by two closely spaced apertures (at equal distances from the source) and the diffracted light overlaps.

“The brighter stripes on each side [of the central bright stripe] are at such distances that the light coming to them from the apertures must have passed through a longer space than that which comes from the other, by an interval which is equal to the breadth of one, two, three or more of the supposed undulations, while the intervening dark spaces correspond to a difference of half a supposed undulation, of one and a half, or two and a half or more.”

- (i) What is meant by ‘*the breadth of an undulation*’? [1]

.....

.....

- (ii) Put Young’s condition for the **third dark** fringe (from the centre) into the form of an equation, giving a simple labelled diagram to help you explain the meanings of terms in the equation. [3]

.....

.....

.....

.....



(b) (i) Describe briefly one discovery which Ampère made by experiment. [2]

.....

.....

.....

(ii) What did Ampère believe was occurring inside a magnet to give rise to its magnetic properties? [2]

.....

.....

.....

(c) In the diagram of Maxwell's vortex ether, an external agency is pushing the shaded zigzag line of idlers steadily in the direction from **A** to **B**.

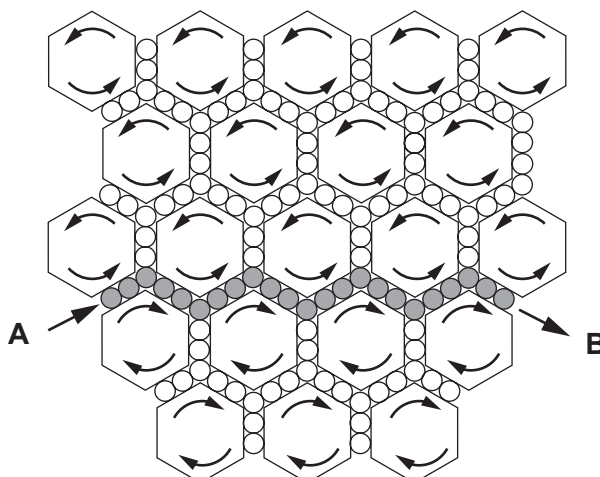

Describe in detail what the pattern of vortex rotation represents in electromagnetic terms. Remember that the diagram is a section through a three-dimensional ether. [3]

.....

.....

.....

.....

.....

.....



- (d) In a thought-experiment, a rod of length 12.0 m moves at a constant velocity through a laboratory, in a direction at right angles to its own length. The rod carries a mirror at one end. A flash of light is sent (event **A**) from the other end, reflects (event **B**) off the mirror and arrives back (event **C**) at the other end. In the laboratory frame of reference the events occur at the places shown.

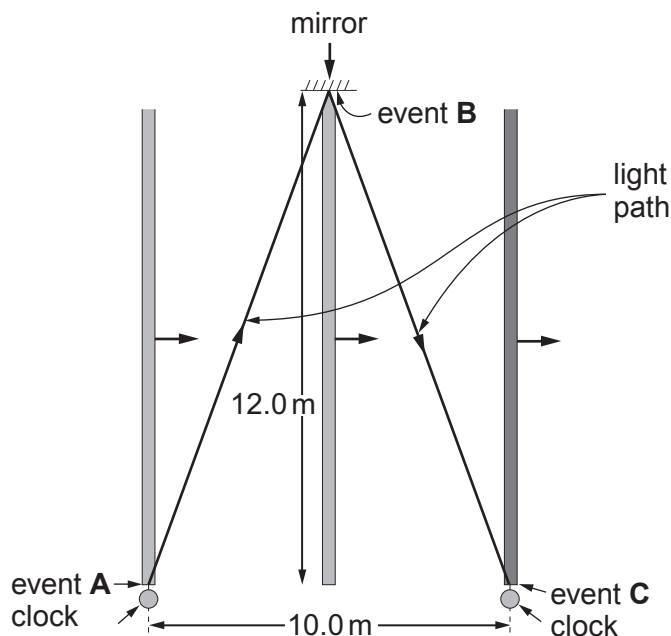

- (i) Calculate the total length of the light path and **hence** show clearly that the time between events **A** and **C**, as measured by synchronised clocks (with suitable sensors), placed as shown in the laboratory, is approximately 87 ns. Give your answer to 3 significant figures. [3]

.....

.....

.....

.....

.....

.....

.....

- (ii) By considering the total length of the light path in the rod's frame (the frame of reference in which the rod is stationary), calculate the time between events **A** and **C** in the rod's frame. [1]

.....

.....

.....



(iii) State the difference between a *proper* and an *improper* time, referring to parts (d)(i) and (ii). [2]

.....

.....

.....

.....

(iv) Calculate to three significant figures the rod's speed in the laboratory frame and hence check the ratio of your answers to parts (d)(i) and (ii) using the time dilation equation. [3]

.....

.....

.....

.....

.....

.....



**Option C: Materials**

9. (a) A specimen of rubber is gradually loaded and then unloaded. A stress-strain diagram for the specimen is shown.

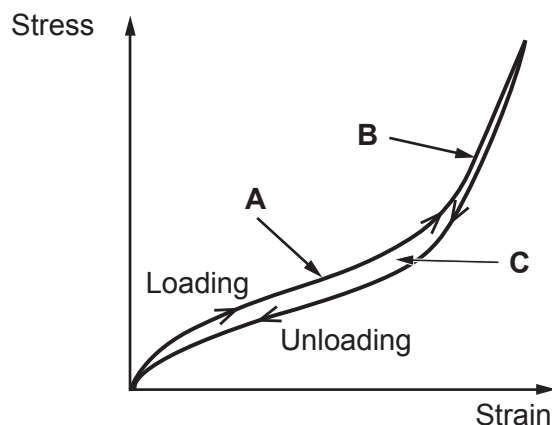

- (i) State the feature of the graph which confirms that the rubber was deformed elastically. [1]

.....

.....

- (ii) By referring to the molecular structure of rubber explain why the gradient at A is less steep than the gradient at B. [3]

.....

.....

.....

.....

.....

.....

.....

- (iii) Write down the name given to the effect represented by the area enclosed between the loading and unloading curve, C and explain the significance of this area. [3]

.....

.....

.....

.....

.....

.....

.....





- (iv) With reference to your answer to part (a)(iii), explain why it is inadvisable to drive cars with tyres which are under-inflated, that is, with less than the recommended air pressure. [1]

.....

.....

.....

- (b) The bar in the figure below is made from two different metals, **P** and **Q**, of equal length  $\frac{L_0}{2}$  and cross-sectional area,  $A$ . The metals are welded securely to each other and to the rigid support.

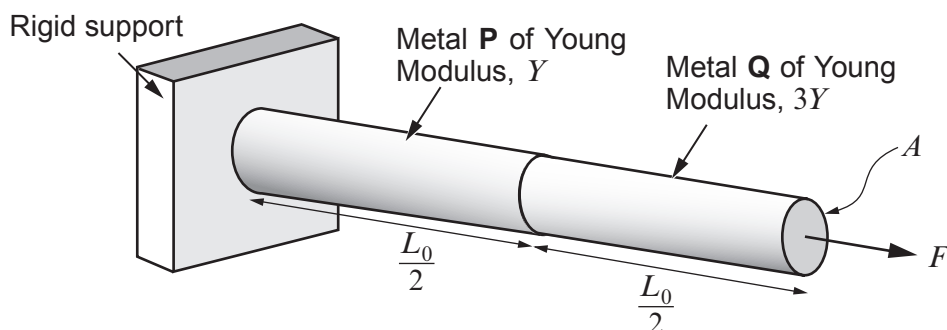

- (i) By considering the total extension of both metals under the action of a common force,  $F$ , show in clear steps that the energy,  $W$ , stored in the combination can be given by: [4]

$$W = \frac{F^2 L_0}{3AY}$$

.....

.....

.....

.....

.....

.....

.....

.....

.....

.....



(ii) A force-extension graph for the combination is shown below.

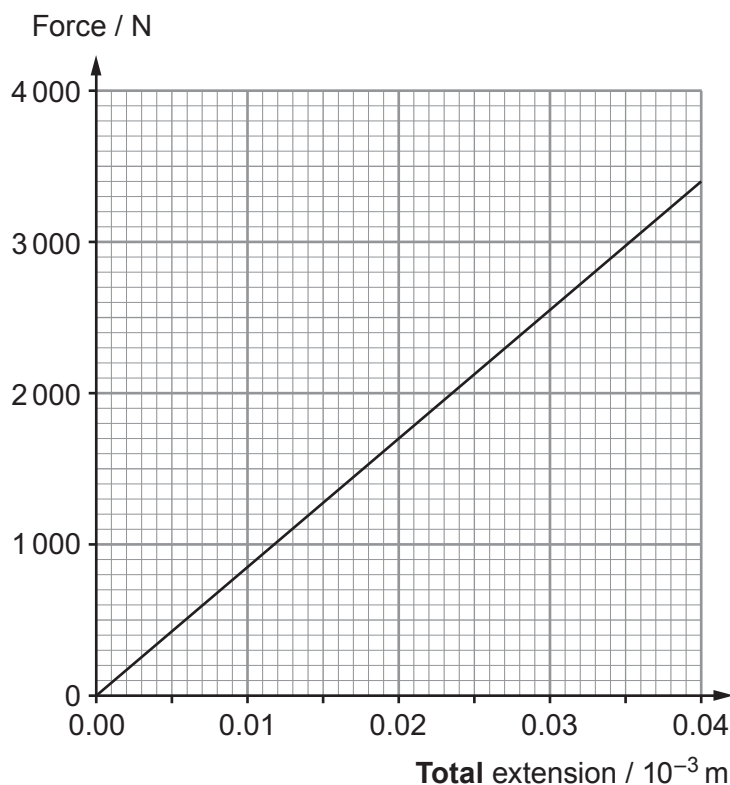

Use the graph to determine the energy stored in the combination when the applied force = 2 800 N. [2]

.....

.....

.....

.....

(iii) Using the equation in part (b)(i) and your answer to part (b)(ii) (or otherwise), determine  $Y$  (the Young modulus of metal **P**). ( $L_0 = 0.300$  m and the diameter of the bars = 14.5 mm.) [3]

.....

.....

.....

.....

.....



(iv) Explaining your reasoning carefully, determine the ratio:

[3]

Examiner  
only

$$\frac{\text{extension of metal P}}{\text{extension of metal Q}}$$

.....

.....

.....

.....

.....

.....



### Option D: Biological Measurement and Medical Imaging

10. The diagram below shows two X-ray spectra produced by X-ray tubes.

Relative intensity

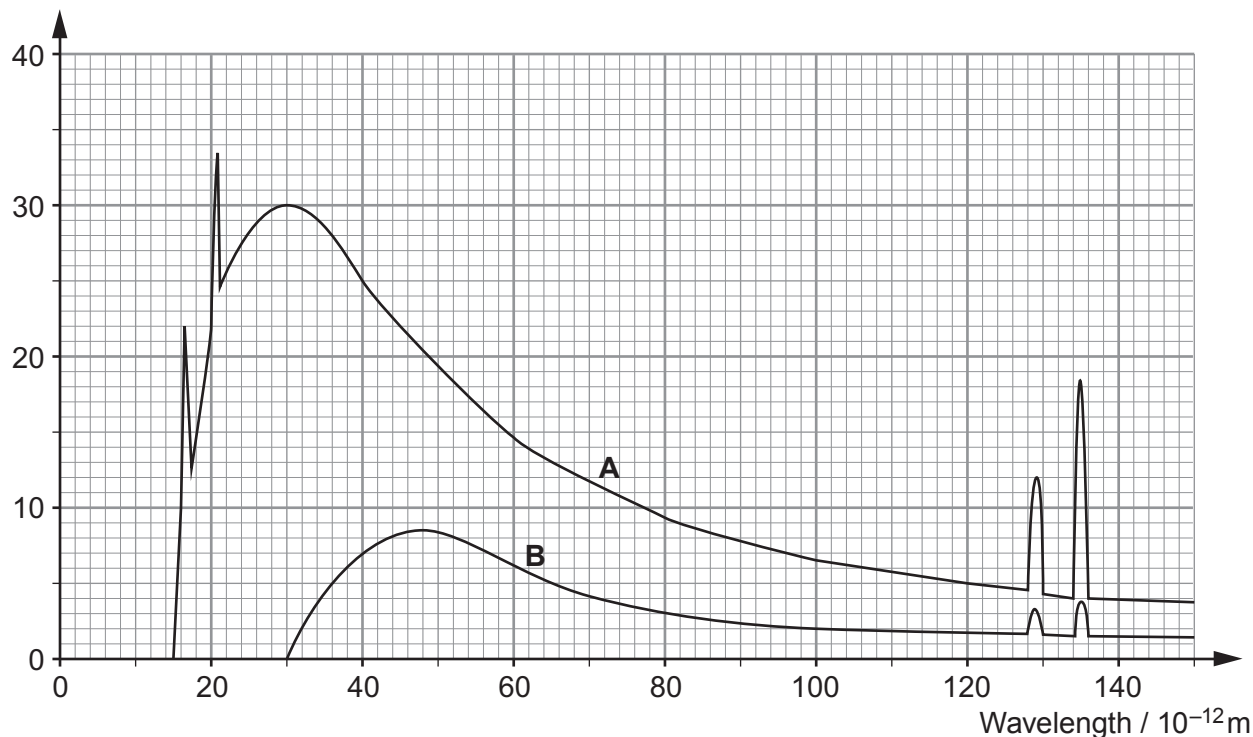

- (a) (i) Without calculation compare the accelerating voltages used to produce the two spectra, **A** and **B**. Explain your reasoning. [2]

.....

.....

.....

.....

- (ii) The target used was of the same material in the two cases. State how the graphs support this statement. [1]

.....

.....



- (iii) Spectrum **A** was produced using an accelerating voltage of 84 kV. Use this to calculate a value for the Planck constant,  $h$  (show your working). [2]

.....

.....

.....

.....

.....

.....

- (iv) Calculate the accelerating voltage used to produce spectrum **B**. [2]

.....

.....

.....

.....

- (b) Both MRI and CT scans can be used in diagnostic medicine. Give **one** advantage and **one** disadvantage (other than cost) of using MRI scans over CT scans. [2]

.....

.....

.....

.....



(c) An ultrasound probe is used to study the flow of blood from the heart.

(i) Explain how the probe produces ultrasound. [3]

.....

.....

.....

.....

.....

.....

(ii) The wavelength of ultrasound used is 0.40 mm and it travels through the blood at  $1200 \text{ ms}^{-1}$ . If the wavelength shift of the received ultrasound is  $0.60 \mu\text{m}$ , calculate the speed of flow of the blood. [2]

.....

.....

.....

.....

(d) An ECG recorder is used to check a patient's heart. Sketch the expected ECG trace for a healthy heart. Both axes should be labelled. [2]



(e) Explain the difference between *absorbed dose* and *dose equivalent* and explain how the *dose equivalent* would be different for exposure to alpha particles and gamma rays. [4]

.....

.....

.....

.....

.....

.....

.....

.....

.....

.....



### Option E: Energy Matters

11. (a) The largest **pumped-storage** hydroelectric scheme in the UK is the Dinorwig power station which is a 1.8 GW facility in Llanberis, North Wales.

Dinorwig



- (i) Explain why the **mean** output power of the Dinorwig station is negative. [2]

.....

.....

.....

.....

- (ii) Explain briefly why the Dinorwig station is extremely useful even though its mean output power is negative. [1]

.....

.....

.....

- (b) The hydroelectric system that produces the greatest energy output in the world is the 7 km long Itaipu dam in South America which has a mean output power of around 11 GW.

Itaipu  
Dam





- (i) State **three** advantages and **one** disadvantage of a hydroelectric power station over a wind farm. [3]

.....

.....

.....

.....

.....

.....

.....

.....

.....

.....

- (ii) The height of the Itaipu dam is 118 m and its mean output power is 11 GW. Determine the mass of water that passes through the Itaipu hydroelectric system daily, stating any assumption that you make. [4]

.....

.....

.....

.....

.....

.....

.....

.....

.....



- (c) (i) Calculate a value for the Solar Constant from the following data. [3]

Temperature of the Sun = 5 780 K, Radius of the Sun =  $6.96 \times 10^8$  m,  
Distance from the Earth to the Sun =  $1.50 \times 10^{11}$  m.

.....

.....

.....

.....

- (ii) The actual value of the light intensity incident upon the Earth's surface having passed through the atmosphere is  $1.12 \text{ kW m}^{-2}$ . Estimate the area of land required to produce the same mean power output as the Itaipu hydroelectric system (11 GW) from solar panels. Explain your reasoning carefully. [3]

.....

.....

.....

.....

.....

- (iii) The cost per square metre of solar panels is around £200 but they have a guaranteed lifetime of 25 years. Compare the cost of producing electricity using solar panels with the normal cost of producing electricity (£40-60 per MWh). [4]

.....

.....

.....

.....

.....

.....

.....

**END OF PAPER**



**BLANK PAGE**

**PLEASE DO NOT WRITE  
ON THIS PAGE**







**GCE A level**

1325/01-B



S16-1325-01B

**PHYSICS – PH5**

**Electromagnetism, Nuclei & Options**

A.M. TUESDAY, 28 June 2016

**CASE STUDY FOR USE WITH  
SECTION B**

**Examination copy**

**To be given out at the start of the examination.**

**The pre-release copy must not be used.**

1325  
01B001

## The Big Bang Theory

Paragraph

(Freely modified from various Wikipedia pages)

The **Big Bang** theory is the prevailing cosmological model for the early development of the universe. The key idea is that the universe is expanding. Consequently, the universe was denser and hotter in the past. Moreover, the Big Bang model suggests that at some moment all matter in the universe was contained in a single point, which is considered the beginning of the universe. Modern measurements place this moment at approximately 13.8 billion years ago, which is thus considered the age of the universe. After the initial expansion, the universe cooled sufficiently to allow the formation of subatomic particles, including protons, neutrons, and electrons. Though simple atomic nuclei formed within the first three minutes after the Big Bang, thousands of years passed before the first electrically neutral atoms formed. The majority of atoms produced by the Big Bang were hydrogen, along with helium and traces of lithium. Giant clouds of these primordial elements later coalesced through gravity to form stars and galaxies, and the heavier elements were synthesized either within stars or during supernovae. 1

The Big Bang theory offers a comprehensive explanation for a broad range of observed phenomena, including the abundance of light elements, the cosmic microwave background radiation (CMBR), large scale structure, and Hubble's Law. Today, the distances between galaxies is increasing hence, in the past, galaxies were closer together. The known laws of nature can be used to calculate the characteristics of the universe in detail back to a time when densities and temperatures were extreme. While large particle accelerators can replicate such conditions, resulting in confirmation and refinement of the details of the Big Bang model, these accelerators can only probe so far into high energy conditions. Consequently, the state of the universe in the earliest instants of the Big Bang expansion is poorly understood and still an area of open investigation. The Big Bang theory does not provide any explanation for the initial conditions of the universe; rather, it describes and explains the general evolution of the universe going forward from that point on. 2

Belgian Catholic priest and scientist Georges Lemaître proposed what became the Big Bang theory in 1927. Over time, scientists built on his initial idea of cosmic expansion, which, his theory went, could be traced back to the origin of the cosmos and which led to the formation of the modern universe. The framework for the Big Bang model relies on Albert Einstein's theory of general relativity and on simplifying assumptions such as homogeneity and isotropy of space. In 1929, Edwin Hubble discovered that the distances to faraway galaxies were strongly correlated with their red shifts. Hubble's observation was taken to indicate that all distant galaxies and clusters have an apparent velocity directly away from our vantage point: that is, the farther away, the higher the apparent velocity, regardless of direction. The interpretation is that all observable regions of the universe are receding from each other. 3

While the scientific community was once divided between supporters of two different expanding universe theories – the Big Bang and the Steady State theory – observational confirmation of the Big Bang scenario came with the discovery of the CMBR in 1964, and later when its spectrum was found to match that of thermal radiation from a black body. 4

## The History of the Universe

Paragraph

### Inflation

The earliest phases of the Big Bang are subject to much speculation. In the most common models the universe was filled homogeneously and isotropically with an incredibly high energy density and huge temperatures and pressures and was very rapidly expanding and cooling. Approximately  $10^{-37}$  seconds into the expansion, a phase transition caused a cosmic inflation, during which the universe grew exponentially. After inflation stopped, the universe consisted of a quark-gluon plasma, as well as all other elementary particles. Temperatures were so high that the random motions of particles were at relativistic speeds, and particle-antiparticle pairs of all kinds were being continuously created and destroyed in collisions. At some point baryogenesis, a reaction that we know little about, violated the conservation of baryon number, leading to a very small excess of quarks and leptons over antiquarks and antileptons – of the order of one part in 30 million. This resulted in the predominance of matter over antimatter in the present universe.

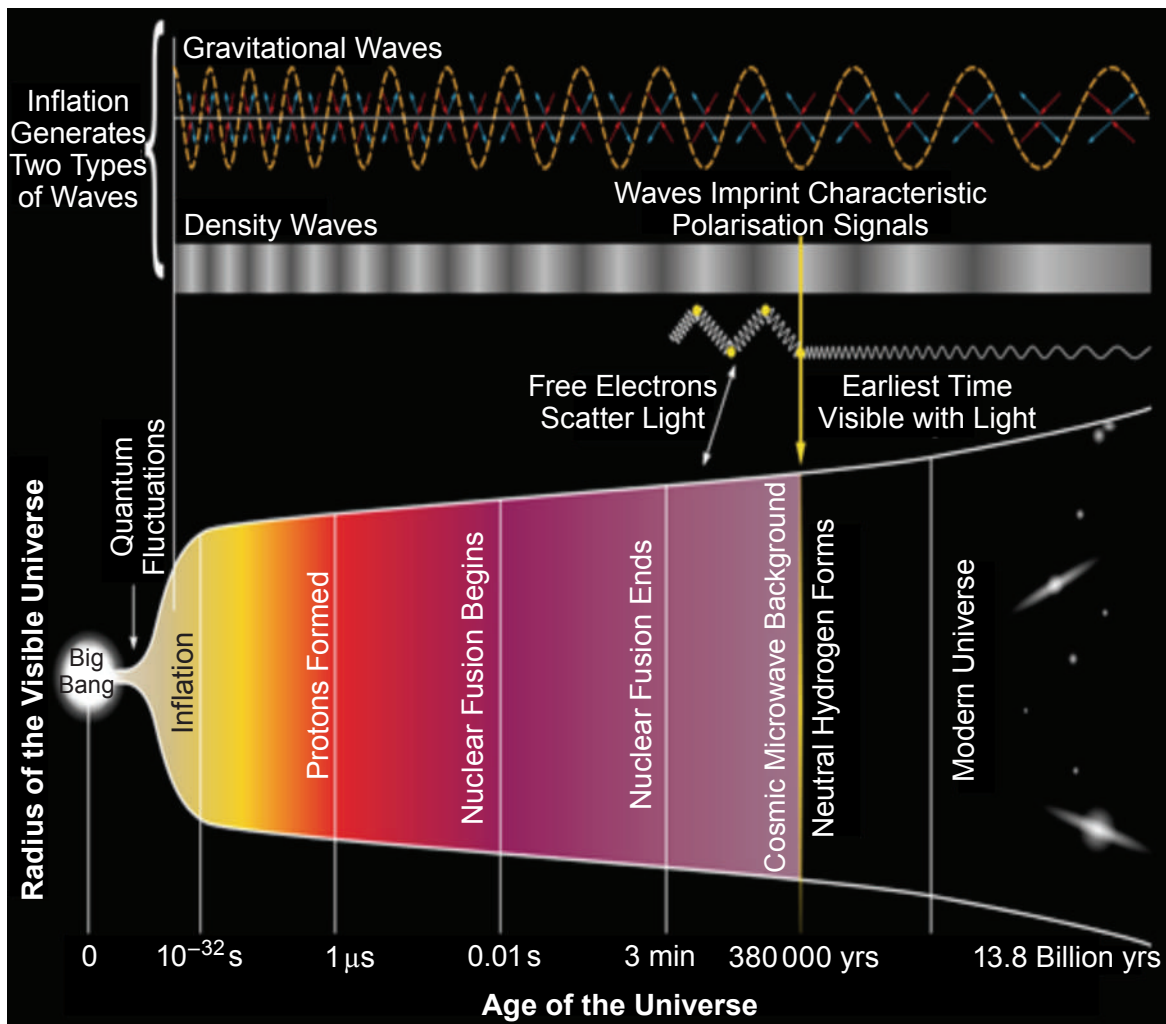

Figure 1

### **Protons Forming**

Paragraph

The universe continued to decrease in density and fall in temperature, hence the typical energy of each particle was decreasing. After about  $10^{-11}$  seconds, the picture becomes less speculative, since particle energies drop to values that can be attained in particle physics experiments. At about  $10^{-6}$  seconds, quarks and gluons combined to form baryons such as protons and neutrons. The small excess of quarks over antiquarks led to a small excess of baryons over antibaryons. The temperature was now no longer high enough to create new proton-antiproton pairs (similarly for neutrons-antineutrons), so a mass annihilation immediately followed, leaving just one in  $10^{10}$  of the original protons and neutrons, and none of their antiparticles. A similar process happened at about 1 second for electrons and positrons. After these annihilations, the remaining protons, neutrons and electrons were no longer moving relativistically and the energy density of the universe was dominated by photons (with a minor contribution from neutrinos). 6

### **Nuclear Fusion Begins and Ends**

A fraction of a second into the expansion, when the temperature was about a hundred billion kelvin (100 GK), neutrons combined with protons to form the universe's deuterium and helium nuclei in a process called Big Bang nucleosynthesis. However, around 3 minutes after the Big Bang the universe had cooled further so that fusion was no longer possible. The Big Bang theory itself predicts mass abundances of about 75% of hydrogen-1, about 25% helium-4, about 0.01% of deuterium, trace amounts (in the order of  $10^{-10}$ ) of lithium and beryllium, and no other heavy elements. That the observed abundances in the universe are generally consistent with these abundance numbers is considered strong evidence for the Big Bang theory. 7

### **The Universe Becomes Transparent**

After about 380 000 years the universe cooled to a temperature of around 3000 K. The electrons and nuclei combined into atoms (mostly hydrogen). This meant that radiation could travel freely without forcing free charges to oscillate and continued through space largely unimpeded. This relic radiation is known as the CMBR. It is frequently stated that the CMBR that is detected today started as gamma radiation shortly after the Big Bang. This is not strictly true because these photons were scattered and absorbed a long time ago. The CMBR that we can detect now started as mainly infra-red radiation 380 000 years after the Big Bang when the universe suddenly became transparent. Although the universe previously had been hot enough to emit gamma rays (as a black body radiator), this radiation was not able to travel very far. 8

### **The Modern Universe and The Big Bang Theory**

In today's universe, the earliest and most direct observational evidence of the validity of the theory are the expansion of the universe according to Hubble's law (as indicated by the red shifts of galaxies), discovery and measurement of the CMBR and the relative abundances of light elements produced by Big Bang nucleosynthesis. More recent evidence includes observations of galaxy formation and evolution, and the distribution of large-scale cosmic structures. These are sometimes called the "four pillars" of the Big Bang theory. 9



Observations of distant galaxies and quasars show that these objects are red shifted – the light emitted from them has been shifted to longer wavelengths. This can be seen by taking a frequency spectrum of an object and matching the spectroscopic pattern of emission lines or absorption lines corresponding to atoms of the chemical elements interacting with the light. These red shifts are distributed evenly among the observed objects in all directions. If the red shift is interpreted as a Doppler shift, the recessional velocity of the object can be calculated. When the recessional velocities are plotted against these distances, a linear relationship known as Hubble's law is observed:

$$v = H_0 D \quad \text{Equation 1}$$

where:

- $v$  is the recessional velocity of the galaxy or other distant object;
- $D$  is the distance to the object;
- $H_0$  is the Hubble constant, measured to be  $2.2685 \times 10^{-18} \text{ s}^{-1}$ .

If Hubble's law,  $v = H_0 D$ , is combined with a simple calculation for the escape velocity from a spherical universe, the so-called critical density of the universe can be calculated:

$$\frac{1}{2} m v_{\text{esc}}^2 - \frac{GMm}{R} = 0 \quad \text{Equation 2}$$

where  $v_{\text{esc}}$  is the escape velocity of an arbitrary mass,  $m$ , which is a distance,  $R$ , from the 'centre' of the universe and  $M$  is the mass of the universe contained inside the sphere of radius  $R$  (upon whose surface the arbitrary mass lies). When the volume of the sphere of radius  $R$  is also included, this leads to:

$$\rho_c = \frac{3H_0^2}{8\pi G} \quad \text{Equation 3}$$

The critical density,  $\rho_c$ , of the universe can be calculated from this equation and corresponds to 5 hydrogen atoms per cubic metre. The observed mass of the universe (based on counting stars) also leads to a similar value of density.

Not only can we calculate a mean density for the modern universe, we can also calculate a mean temperature. From the CMBR, if the universe is assumed to be a black body then a temperature of  $(2.725 \pm 0.001)\text{K}$  is obtained. Moreover, the microwave spectrum follows a perfect black body spectrum shape.

Intensity/arbitrary units

Paragraph

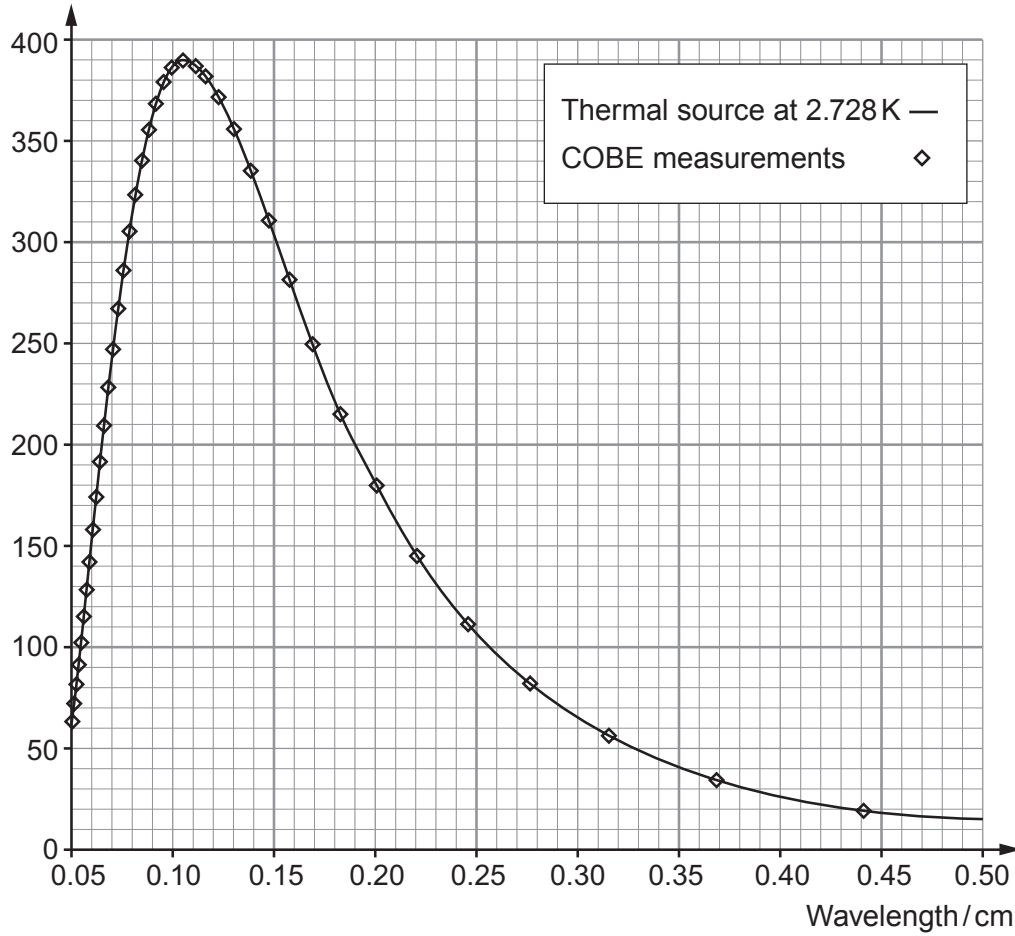

Figure 2

Since the early 1980s more and more evidence for larger scale order of matter in the universe has been discovered. Stars are organised into galaxies, which in turn form galaxy groups, galaxy clusters, superclusters, sheets, walls and filaments, which are separated by immense voids, creating a vast foam-like structure sometimes called the “cosmic web”. All these enormous scale structures have been simulated by computer and all seem to agree with the Big Bang theory. <sup>14</sup>

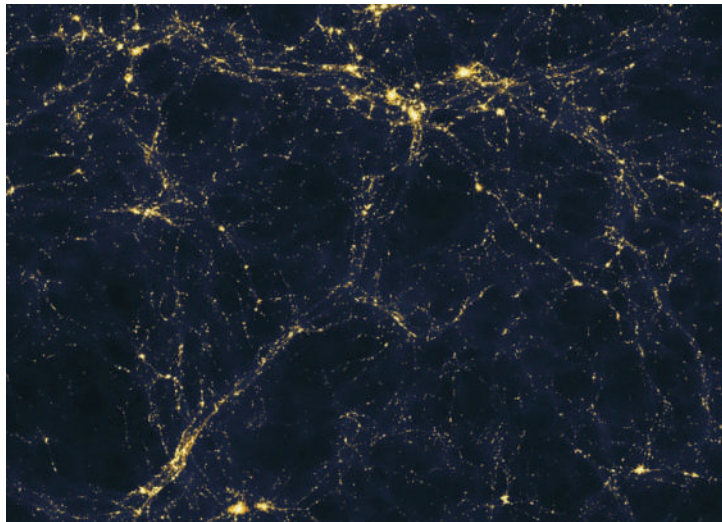

Figure 3

**BLANK PAGE**